

8 7 6 5 4 3 2 1

LIST OF MATERIAL (QUANTITY FOR ONE UNIT)

ITEM NO.	QTY RQD	DESCRIPTION	LAST NO USED	SIZE RQD	MTL SPEC	MTL REQ	PART NO.	SCE	UNIT WT	REMARKS	REVISIONS						
											REV	ZONE	DESCRIPTION	BY	DATE	APPROVED	
1	2 SF	PLATE, 10.2# (1/4 NOM)		2	2	OSS	STEEL		IAF	10.20		XX	XXX	XXXXXXXXXXXX	XX	XX/XX	XXXX
2	3 FT	ANGLE, 2x2x1/4		2	2	OSS	STEEL		IAF	3.19							
3	1 EA	PIPE, 1 NPS, TOE, SCH 40, L=24				GALV	STEEL		IAF	1.68	Lbf PER FOOT						
4	1 EA	PIPE, 1 NPS, TBE, SCH 40, L=24				GALV	STEEL		IAF	1.68	Lbf PER FOOT						
5	1 EA	NIPPLE, 1 NPS, SCH 40, L= 2				GALV	STEEL		IAF	0.13							
6	2 EA	ELBOW, 90°, 1 NPS				GALV	STEEL		IAF	0.20							
7	1 EA	CAP, PIPE, 1 NPS				GALV	STEEL		IAF	0.12							
9	1 FT	BAR, FLAT, 3x3/8				6061	AL		IAF	1.32	ANY GRADE AL IS ACCEPTABLE						
10	1 FT	BAR, SQUARE, 3x3				6061	AL		IAF	10.53	ANY GRADE AL IS ACCEPTABLE						
11	4 EA	CAPSCREW, SOCKET HEAD, 1/4-20UNC2A				CRES	STEEL		IAF	.03							
		1/4-20UNC2A, L = 1-1/2															
12	4 EA	CAPSCREW, SOCKET HEAD,				CRES	STEEL		IAF	.08							
		5/16-18UNC2A, L = 2-1/4															
13	2 EA	WASHER, FLAT, 1/4 NOM				CRES	STEEL		IAF	.01							
14	2 EA	WASHER, LOCK, SPLIT, 1/4 NOM				CRES	STEEL		IAF	.01							
15	6 EA	BOLT, CARRIAGE,				CRES	STEEL		IAF	.08							
		3/8-16UNC2A, L = 1-1/2															
16	6 EA	BOLT, HEX HEAD,				CRES	STEEL		IAF	.08							
		3/8-16UNC2A, L = 1															
17	10 EA	WASHER, FLAT, 3/8 NOM				CRES	STEEL		IAF	.01							
18	8 EA	WASHER, LOCK, SPLIT, 3/8 NOM				CRES	STEEL		IAF	.01							

GENERAL NOTES

- GN-1. THIS DRAWING WAS DEVELOPED FOR ACCOMPLISHMENT OF FABRICATION OF A SYSTEM TO ALLOW WHEELCHAIR BOUND PERSONS TO PARTICIPATE IN ARCHERY SPORTING EVENTS..
- GN-2. THE PURPOSE OF THIS DRAWING IS TO PROVIDE THE NECESSARY DIMENSIONS, MATERIAL REQUIREMENTS, AND INFORMATION TO FABRICATE A WHEELCHAIR ARCHERY BOW MOUNTING STAND.
- GN-3. ENGINEERING DATA SUPPORTING THIS DRAWING IS NOT REQUIRED.
- GN-4. AN ASTERISK (\*) APPEARING OPPOSITE A REFERENCE DENOTES A REQUIRED REFERENCE. A REQUIRED REFERENCE IS A REFERENCE NECESSARY FOR DEVELOPMENT OF ESTIMATES, MATERIAL ORDERING, OR ACCOMPLISHMENT OF INDUSTRIAL WORK.
- GN-5. ALL ABBREVIATIONS ARE PER ASME STD. Y14.38M-2002 EXCEPT AS FOLLOWS:  
IAF = INSTALLING ACTIVITY FURNISHED  
GFM = GOVERNMENT FURNISHED MATERIAL  
S = SCRAP
- GN-6. THE ORIGIN OF A VIEW IS INDICATED BY ZONE LETTERS AND NUMBERS IN PARENTHESES BELOW THE VIEW.
- GN-7. GRIND SMOOTH ALL SHARP CORNERS, BURRS AND RAGGED EDGES LIABLE TO CAUSE INJURY TO PERSONNEL OR DAMAGE TO EQUIPMENT.
- GN-8. ALL FABRICATION, WELDING, AND INSPECTION SHALL BE IN ACCORDANCE WITH GOOD ENGINEERING PRACTICES.

SPECIAL NOTES

- SN-1. MATERIAL ITEMS 9 & 10 (ALUMINUM) CAN BE OBTAINED FROM SPEEDY METALS @ WWW.SPEEDYMETALS.COM
- SN-2.

THIS DOCUMENT IS THE SOLE PROPERTY OF CEMCE, LLC. USE OF THIS DRAWING IN WHOLE OR IN PART REQUIRES THE WRITTEN CONSENT OF CHARLES E. MANN, P.E. PRINCIPAL OF CEMCE, LLC.

CONTRACT NO. PRO BONO  
CEMCE, INC.  
221 BROADWAY ROAD  
WINDSOR BEACH, FL 32092  
(377) 499-0810  
CEMCEPROBONO.NET

CEMCE, LLC.  
**WHEEL CHAIR ARCHERY STAND**

90																			
80																			
70																			
60																			
50																			
40																			
30																			
20																			
10																			
0																			

1	NO REFERENCES	NONE																	
NO	TITLE/DESCRIPTION	NO./IDENTITY																	
	REFERENCES																		

U.O.	PRO BONO								
SIZE	F	CAGE	NONE	WBS	110	NUMBER	CEMCE-12-105	REV	-
SCALE:	NTS				SHEET 1 OF 1				

8 7 6 5 4 3 2 1

16 15 14 13 12 11 10 9

F  
E  
D  
C  
B  
A

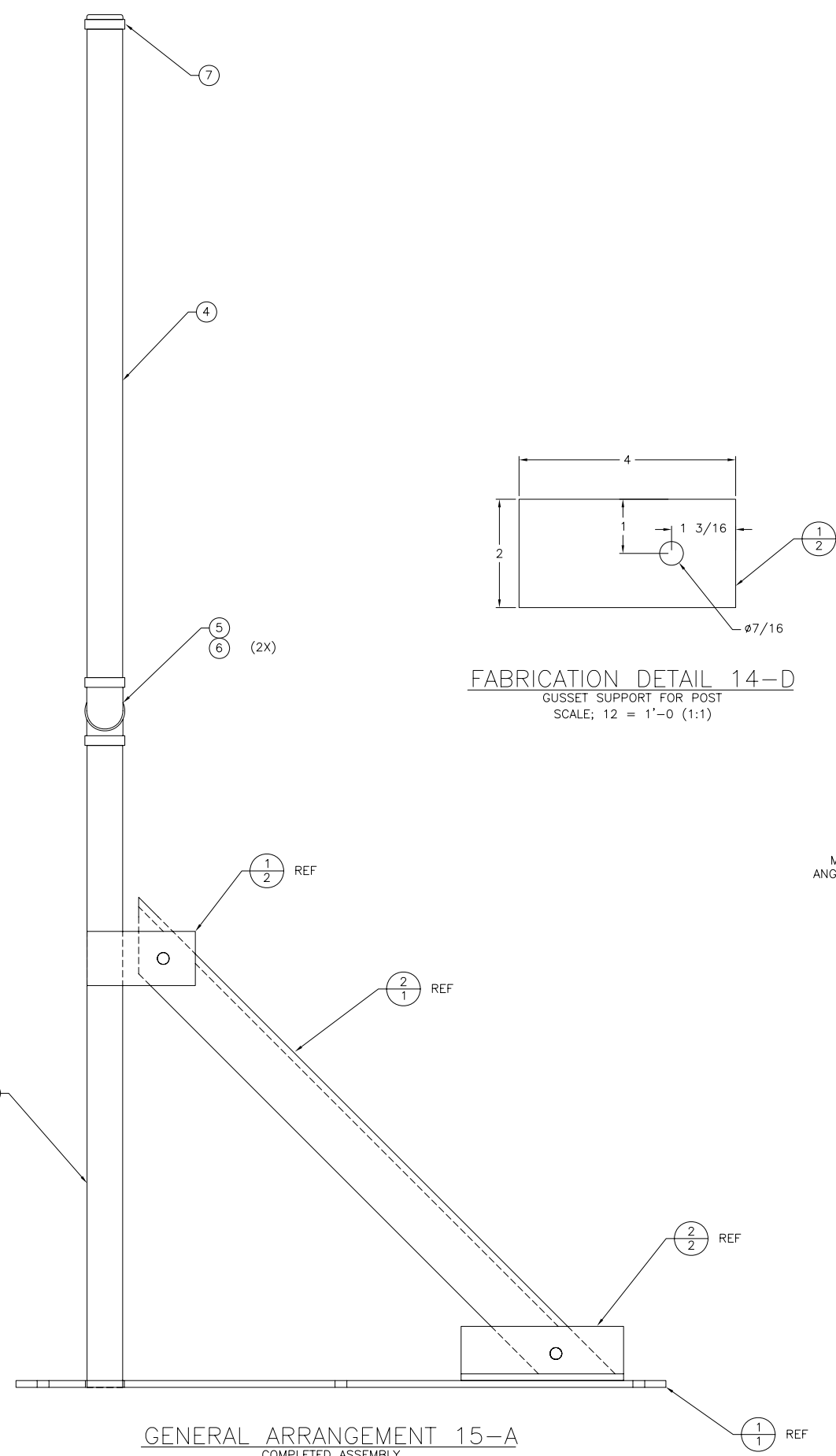

**GENERAL ARRANGEMENT 15-A**  
COMPLETED ASSEMBLY  
SIDE ELEVATION  
SCALE: 6 = 1'-0 (1:2)

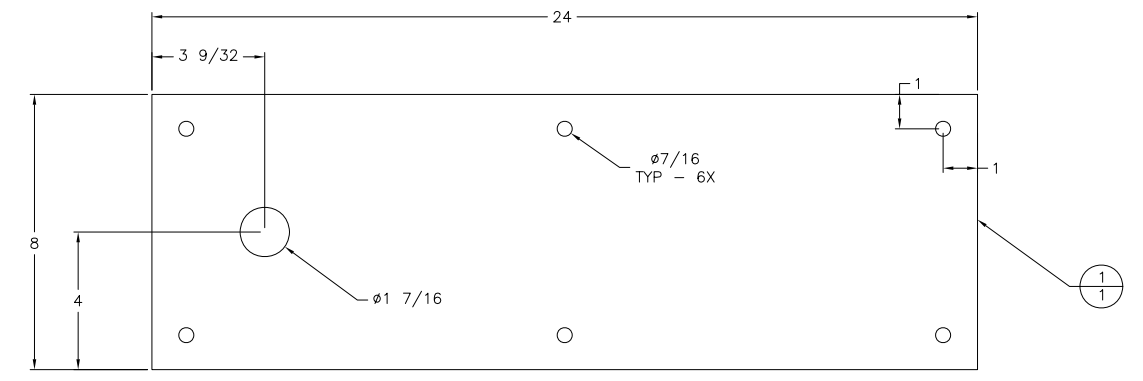

**FABRICATION DETAIL 11-E**  
STAND BASE PLATE  
SCALE: 6 = 1'-0 (1:2)

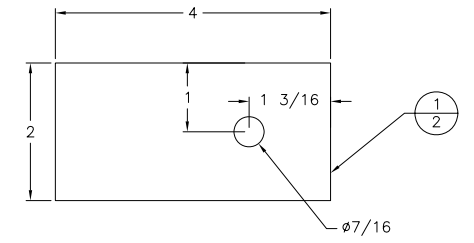

**FABRICATION DETAIL 14-D**  
GUSSET SUPPORT FOR POST  
SCALE: 12 = 1'-0 (1:1)

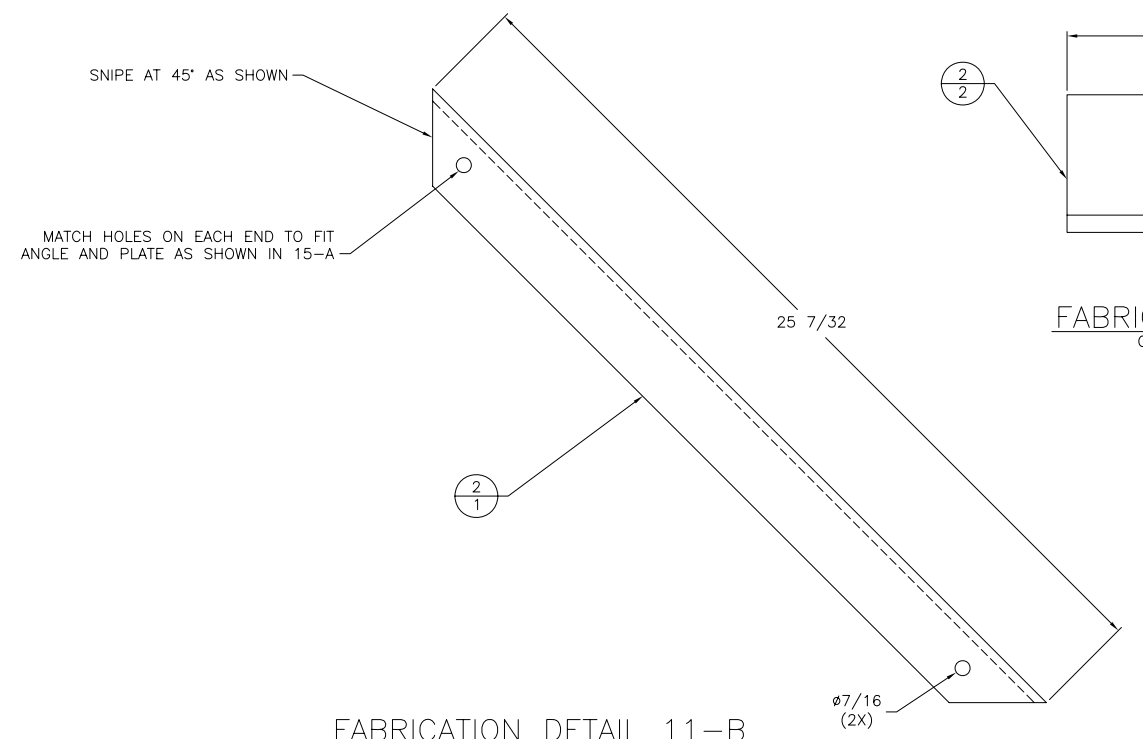

**FABRICATION DETAIL 11-B**  
GUSSET  
SCALE: 6 = 1'-0 (1:2)

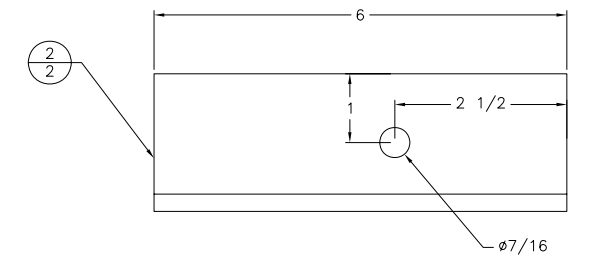

**FABRICATION DETAIL 9-C**  
GUSSET SUPPORT FOR BASE  
SCALE: 12 = 1'-0 (1:1)

SIZE	CAGE	WBS	NUMBER	REV
F	NONE	110	CEMCE-12-105	-
SCALE: AS SHOWN			SHEET 2	

16 15 14 13 12 11 10 9

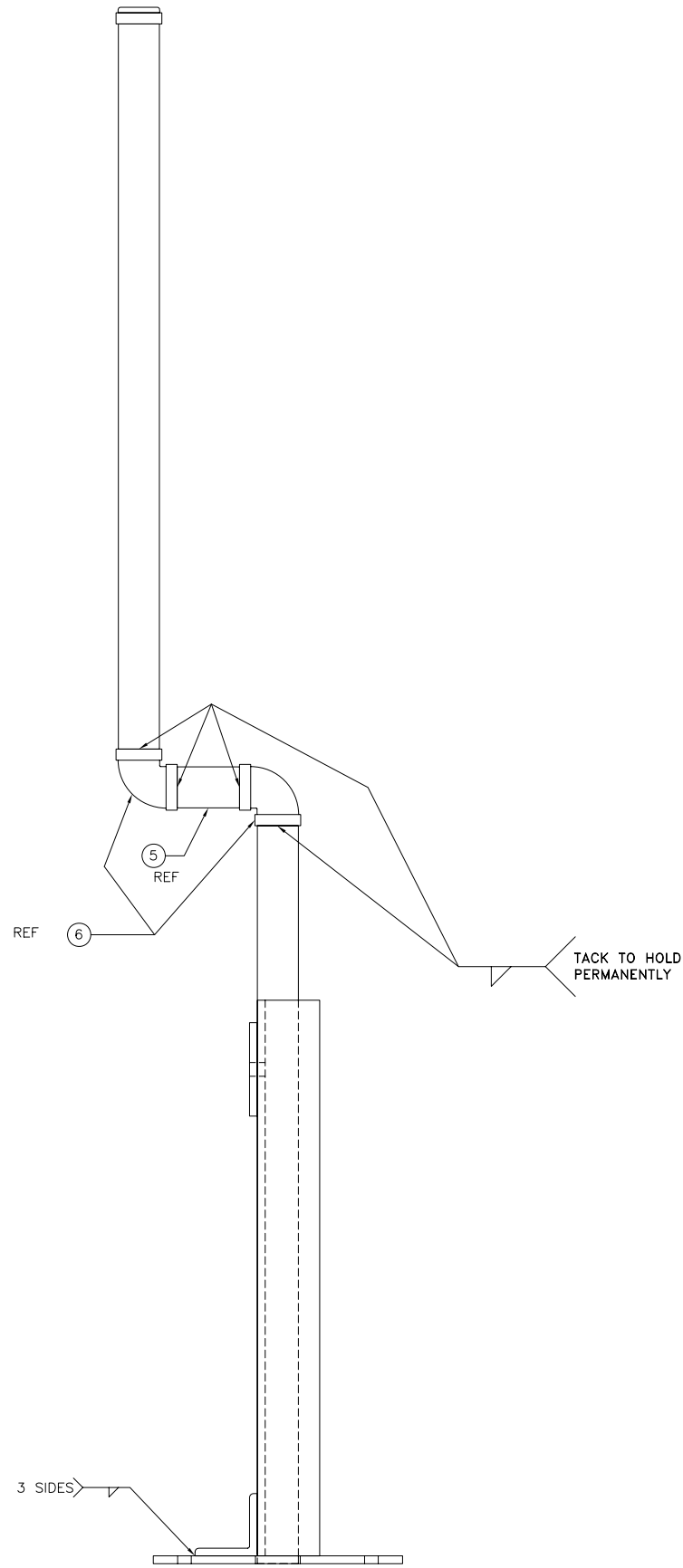

GENERAL ARRANGEMENT 14-A  
 COMPLETED ASSEMBLY  
 END ELEVATION  
 SCALE: 6 = 1'-0 (1:2)

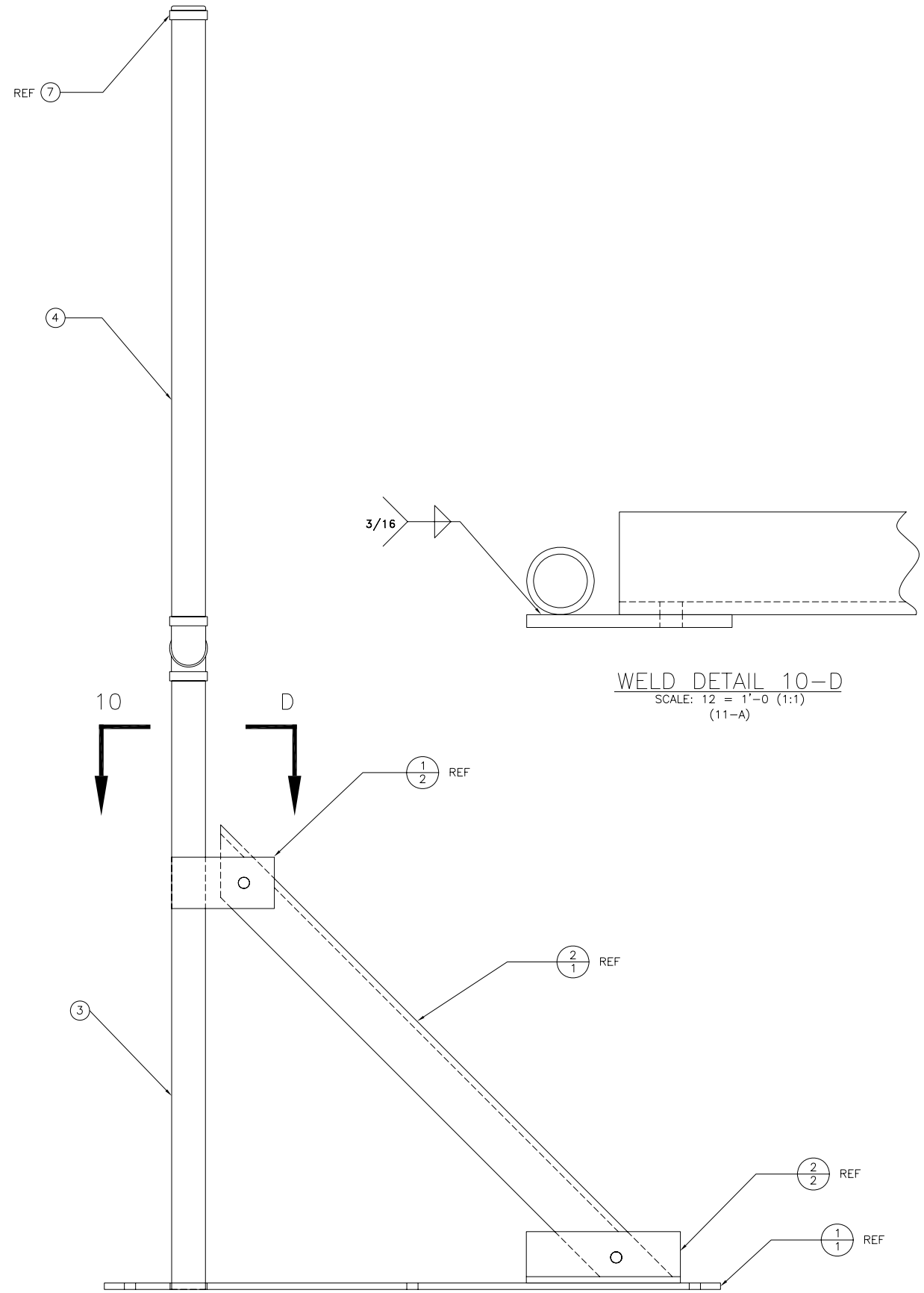

GENERAL ARRANGEMENT 11-A  
 COMPLETED ASSEMBLY  
 SIDE ELEVATION  
 SCALE: 6 = 1'-0 (1:2)

SIZE	CAGE	WBS	NUMBER	REV
F	NONE	110	CEMCE-12-105	-
SCALE: AS SHOWN			SHEET 3	

32

31

30

29

28

27

26

25

F

E

D

C

B

A

F

E

D

C

B

A

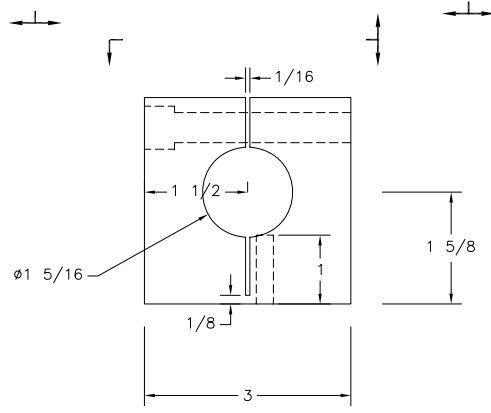
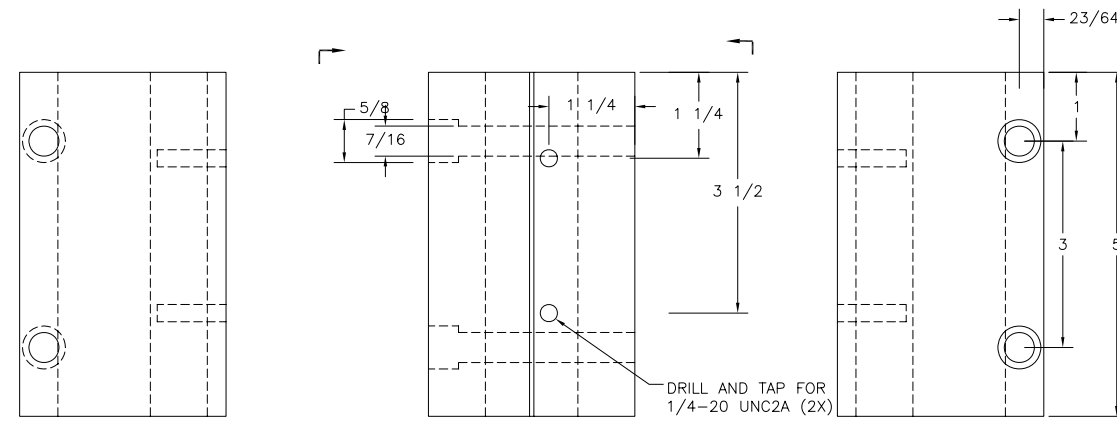

FABRICATION DETAIL XX-X  
MOUNTING BLOCK

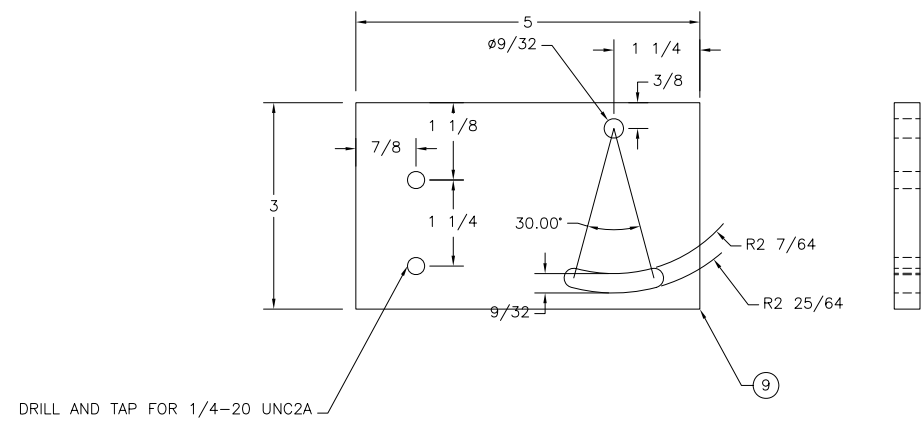

FABRICATION DETAIL XX-X  
BOW MOUNTING AND ADJUSTING PLATE  
(TO ATTACH TO MOUNTING BLOCK)

SIZE	CAGE	WBS	NUMBER	REV
F	NONE	110	CEMCE 12-105	-
SCALE: 12 = 1'-0			SHEET 4	

32

31

30

29

28

27

26

25